

MET ONE 7000 SERIES REMOTE AIRBORNE PARTICLE COUNTERS



*Highest accuracy non-viable
particle monitoring for
EC/FDA compliance*



www.hachultra.com

EXCELLENCE IN PROCESS ANALYTICS

MET ONE 7000 SERIES

The MET ONE 7000 remote airborne particle counters provide the most accurate continuous monitoring for the aseptic and sterile pharmaceutical production environments.

Designed to meet the new rigorous calibration standard ISO 21501, the MET ONE 7000 delivers superior count accuracy of the EC/FDA regulated 0.5 and 5.0 µm non-viable particles and enhanced sample volume accuracy for 1 m³ samples.

ISO 21501 compliant remote airborne particle counters with flexible communications and advanced user notification

The MET ONE 7000 remote particle counters are designed using patented technology to comply with new ISO 21501 calibration requirements that ensure measuring particles of 0.3 µm to 10.0 µm with accuracy and repeatability. With flexible communication and OPC server options, the MET ONE 7000 easily integrates to any Facility Monitoring System. Built-in indication lights notify users of particle events such as reaching an alarm or alert level, eliminating the need to install additional hardware in the sterile environment.

The optical components are made of vaporous hydrogen peroxide (VHP) tolerant materials, and effectively sealed 316L stainless-steel enclosure with sealed power, communication and vacuum connectors. These features make the MET ONE 7000 tolerant to typical VHP based disinfecting cycles and washdown processes used in cleanrooms. Features such as DIP switches for address setting, quick-connect cables and tubing reduce instrument removal and reinstallation time during routine calibration and maintenance work. Built with Long Life Laser™ technology and supported by dependable after sales support from HACH ULTRA, the MET ONE 7000 minimizes cost of ownership and offers unparalleled user experience in product quality and reliability.

ISO 21501 Compliance

ISO 21501 is a new calibration standard replacing ASTM F328 and other similar existing standards. Manufacturers using cleanrooms classified under ISO 14644 are recommended to use ISO 21501 for calibration of their optical airborne particle counters. Additional testing required by ISO 21501 such as counting efficiency and sizing resolution ensure that an ISO 21501 compliant counter identifies the particle size correctly and counts the particles accurately in a low particle concentration, ultra pure cleanroom environment. It also ensures consistency, repeatability and reproducibility across other counters.

Benefits

- Improves confidence in data quality with accurate and reliable particle counting.
- Reduces downtime through instant troubleshooting with advanced user notification lights for flow, sensor, communication, alarm and alert with built-in or external lights.
- Easy to integrate with any FMS system through multiple communication options including Serial Modbus, Ethernet, Analog and Wireless.
- Protects against accidental exposure to VHP and washdown liquid jet.
- Lowest cost of ownership with patented Long Life Laser™ technology.
- Data integrity and security assurance through 21 CFR Part 11 compliance with Hach Ultra FMS software.
- Reduces time and cost of routine calibration and maintenance with quick connect accessories.
- Eliminates risk of data loss with uninterrupted continuous monitoring and storage capacity of up to 1000 data records.

- Enhanced accuracy with ISO 21501 certified calibration
- Built-in user notification for particle monitoring events
- Integrates to any FMS system
- VHP tolerant optics, washdown resistant enclosure
- Proven reliable Long Life Laser™ diode
- 0.3 to 10.0 µm detection range



Port Sizes	Model 7005	0.32 cm (1/8-inch) ID inlet	0.64 cm (1/4-inch) ID outlet
	Model 7015	0.64 cm (1/4-inch) ID inlet	0.64 cm (1/4-inch) ID outlet
Flow Rate	Model 7005	0.1 CFM (2.83 LPM)	
	Model 7015	1.0 CFM (28.3 LPM)	
Sensitivity	Model 7005	0.3 µm at 0.1 CFM (2.83 LPM)	
	Model 7015	0.5 µm at 1.0 CFM (28.3 LPM)	
Range	Model 7005	0.3 µm to 10.0 µm at 0.1 CFM (2.83 LPM)	
	Model 7015	0.5 µm to 10.0 µm at 1.0 CFM (28.3 LPM)	
Channel Sizes		STANDARD 2-CHANNEL	OPTIONAL 4-CHANNEL
	Model 7005 Model 7015	0.5 and 5.0 µm 0.5 and 5.0 µm	0.3, 0.5, 1.0 and 5.0 µm 0.5, 1.0, 5.0 and 10.0 µm
Counting Efficiency	Model 7005	50% at 0.5 µm	
	Model 7015	50% at 0.5 µm	

Performance Specifications

Light Source	Long Life Laser™ diode
Weight	AC version: 3.73 kg (8.2 lbs) DC version: 3.67 kg (8.1 lbs)
Dimensions	22.9 W x 12.5 D x 16.0 H cm (9.02 x 4.92 x 6.3 inches)
Enclosure	316L stainless-steel sealed enclosure with sealed connectors suitable for washdown area
Status Indicator	Multi-colored LED for normal status, count alarm, count alert, sensor failure, flow failure or communication failure
Power Requirements	24 VDC ±10% or 100 to 230 VAC 50/60 Hz
Power Consumption	Ethernet unit: 6.9 W for DC, 8.9 W for AC maximum Serial unit: 5.9 W for DC, 7.6 W for AC maximum Analog Unit: 6.1 W for DC, 7.9 W for AC maximum
Operating Temperature	10 to 32 °C (50 to 90 °F), 5 to 95% relative humidity, non-condensing
Storage Temperature	-40 to 70 °C (-40 to 158 °F), 5 to 98% relative humidity, non-condensing
Signal Output Options	Ethernet with TCP/IP protocol Serial RS-485 with Modbus RTU or FXB communication protocol Analog 4–20 mA
Vacuum Requirements	At least 40.6 cm (16 inches) Hg
Number of Size Channels	Standard 2 or Optional 4
Flow Control	Through critical orifice
Isolation Valve	Built-in solenoid valve
Coincidence Loss	Model 7005: 5% at 2,000,000 particles/ft ³ (70,600,000 particles/m ³) Model 7015: 5% at 400, 000 particle/ft ³ (14,000,000 particles/m ³)
False Count Rate	One or less in five minutes
Accessories Included	Mounting Plate, Isokinetic Probe, Wall Plate, Connector Umbilical Cables and Tubing, Operator Manual
How To Order	20887_5-N_--_--_--

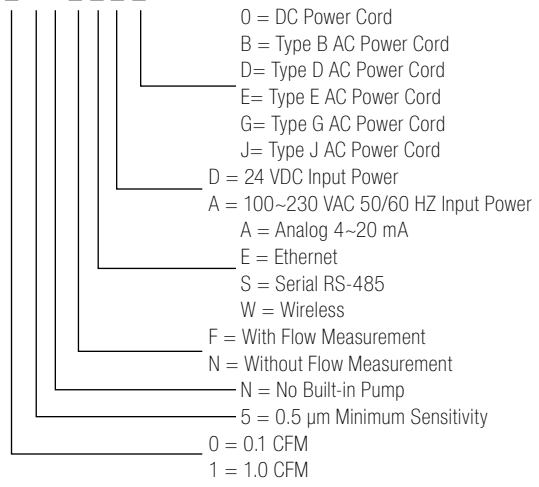

Optional Accessories

- Optional 4-Channel Setting
- Purge Filters, 1.0 CFM 1/4 Tube and 0.1 CFM 1/8 Tube
- Isokinetic Probes, 0.1 CFM and 1.0 CFM
- Cable, Service Port Connector with RS-232 Converter
- Relative Humidity/Temperature Probe
- Brackets, for RH/Temp Probe and LED Indicator Stack/Isokinetic Probe
- Remote Indicator Light Assembly
- Cable Assembly, 3 m for Remote Indicator Light Assembly
- Power Supply Unit, 24 VDC @ 5.0 A, Universal Input for FMS

For a comprehensive parts and accessories list, please refer to the user manual.



Global Headquarters
6, route de Compois, CP 212
1222 Vérenaz, Geneva, Switzerland
Tel +41 (0)22 594 64 00
Fax +41 (0)22 594 64 99

Americas Headquarters
481 California Avenue
Grants Pass, Oregon 97526, USA
Tel 1 800 866 7889 / +1 541 472 6500
Fax +1 541 472 6170

